

A

B

C

D

E

F

A

B

C

D

E

F

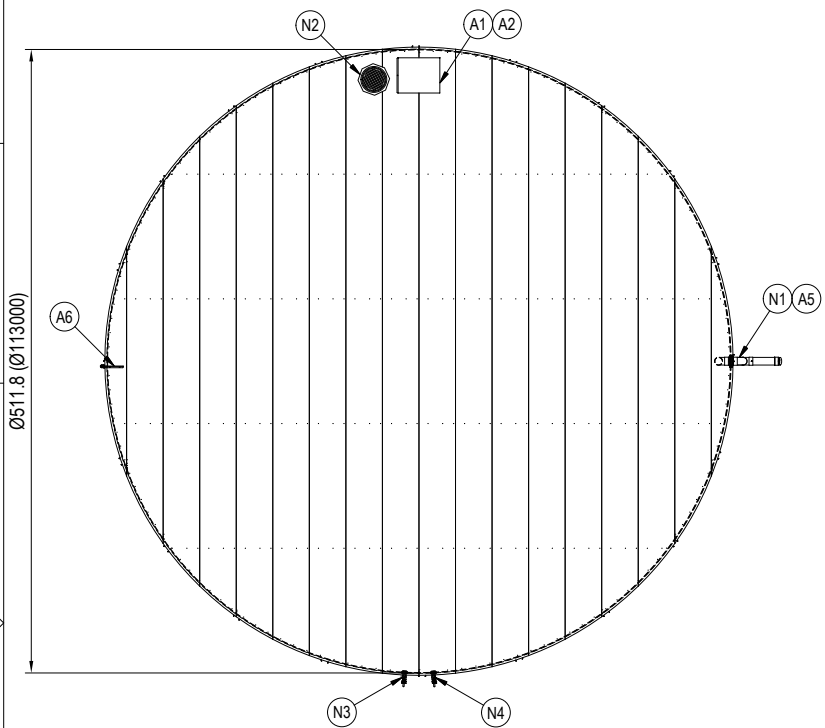

**TANK PLAN**  
SCALE: 1:100

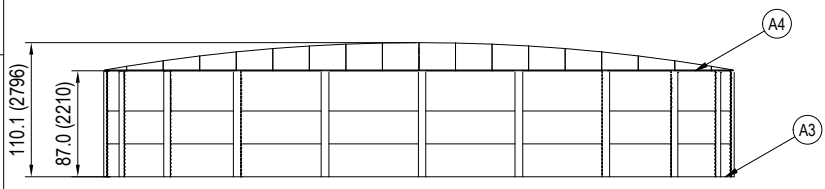

**TANK ELEVATION**  
SCALE: 1:100

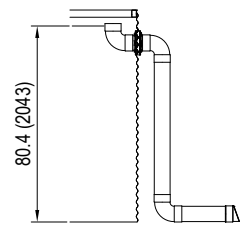

**OVERFLOW**  
SCALE: 1:50

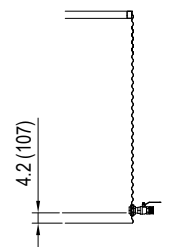

**OUTLET**  
SCALE: 1:50

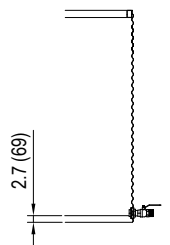

**DRAIN**  
SCALE: 1:50

MANUFACTURER	AQUAMATE
MODEL	UR3D512-MT
GROSS CAPACITY	77,500 GALLONS
NET CAPACITY	67,900 GALLONS
SHELL COLOR / FINISH	NO COLOR / GALVANIZED FINISH
SHELL MOISTURE BARRIER	20mil UNSUPPORTED PE
LINER	ENVIROLINER 20mil
ROOF SHEETING	CORRUGATED 2.67" PITCH 7/8" DEPTH

ID	ACCESSORIES
A1	30" HINGED ROOF ACCESS HATCH
A2	LIGHT DUTY LADDER - 3 RING TANK
A3	512" GEOMAT
A4	DUST AND VERMIN PROTECTION
A5	6" PVC OVERFLOW PIPEWORK
A6	MECHANICAL LEVEL GAUGE

**NOTES**

**GENERAL**

- DRAWINGS TO BE READ IN CONJUNCTION WITH DESIGN SPECIFICATION
- EFFECTIVE VOLUME CALCULATION BASED ON STORAGE LOSS BELOW INVERT OF THE LOWEST OUTLET AND FROM 1" BELOW THE INVERT / LIP OF THE LOWEST OVERFLOW

**PRODUCTION**

- ALL PIPEWORK & VALVES, UNLESS SPECIFIED, BY OTHERS

**INSTALLATION**

- ENSURE FIRM FLAT AND LEVEL SITE IS PROVIDED, AS PER SITE PREPARATION SPECIFICATION, PRIOR TO COMMENCING CONSTRUCTION
- ORIENTATION OF ALL FITTINGS TO BE CONFIRMED PRIOR TO INSTALLATION
- INSTALLATION TOLERANCES APPLY ON TOP OF STANDARD PRODUCTION TOLERANCES

87.0	77,500
85.5	76,100
82.5	73,500
79.5	70,800
76.5	68,100
73.5	65,500
70.5	62,800
67.5	60,100
64.5	57,400
61.5	54,800
58.5	52,100
55.5	49,400
52.5	46,800
49.5	44,100
46.5	41,400
43.5	38,700
40.5	36,100
37.5	33,400
34.5	30,700
31.5	28,100
28.5	25,400
25.5	22,700
22.5	20,000
19.5	17,400
16.5	14,700
13.5	12,000
10.5	9,400
7.5	6,700
4.5	4,000
1.5	1,300
INCHES	US GAL
Ø512" TANK	
DEPTH CHART	

ID	DESCRIPTION	SIZE	TYPE	LVL.	MATERIAL	VALVE TYPE	INTERNAL
N1	OVERFLOW	6"	SDR 35	73.5	ASA	-	VERTICAL ORIFICE
N2	INLET	20"	BASKET	87.0	PP / PE	-	UV GUARD
N3	OUTLET	2"	Sch 40	5.25	GFN	Ni COATED BALL	HORIZONTAL ORIFICE
N4	DRAIN	2"	Sch 40	3.75	GFN	Ni COATED BALL	HORIZONTAL ORIFICE

REV.	DESCRIPTION	DATE	DRAWN	APPROVED
2	ACCESS HATCH ORIENTATION CHANGED	23 MAY 18	ACG	--
1	FIRST ISSUE	16 NOV 16	BAF	--

**AQUAMATE**  
 aquamatetanks.com  
 4132 Atlanta Hwy, Suite 110  
 #314, Loganville GA 30052  
 844.320.8265  
 info@aquamatetanks.com

DRAWN BY:	INIT.	DATE	DESCRIPTION
CHECKED			
APPROVED			
ISSUED			

**77,000 GALLON TANK - MT CONFIGURATION**  
**AQUAMATE TANKS**  
**GENERAL ARRANGEMENT**

INCHES (MILLIMETRES)	SCALE	SHEET	Weight	PROJ. No.	DWG No.	REV.	SHEET SIZE
	REFER SHEET	1 of 1		D030	U-13.0-1000-00001		A ANS